

Rotax MAX Engines Technical Specification 2021

1. Technical Specification within the engine seal for Rotax MAX kart engines

1.1. Squish gap

The crankshaft must be turned by hand slowly over top dead center to squeeze the tin wire.

The squish gap must be measured on the left and right side in the direction of the piston pin.

The average value of the two measurements counts.

125 Mini MAX, 125 Junior MAX, 125 Senior MAX, 125 MAX DD2:

125 Mini MAX	minimum = 1,20 mm
125 Junior MAX	minimum = 1,20 mm
125 Senior MAX	minimum = 1,00 mm
125 MAX DD2	minimum = 1,30 mm

The squish gap must be measured with a certified slide gauge and by using a 2 mm tin wire (Rotax 580130).

125 Micro MAX:

125 Micro MAX minimum = 2,40 mm

The squish gap must be measured with a certified slide gauge and by using a 3 mm tin wire (Rotax 580132).

To achieve the defined minimum squish gap one spacer (Rotax 626420, with same shape as cylinder base gasket) in combination with at least two cylinder base gaskets (one below the spacer and one above the spacer) must be used.

1.2. Combustion chamber insert

Cast identification code has to be "223389" or "223389 1" or "223389 2" or 223389 2/1" or "223389 2/2".
Casted wording "ROTAX" and/or "MADE IN AUSTRIA" must be shown.

Height of combustion chamber insert has to be 28,80 mm +/- 0,2 mm (H).

The profile of the combustion chamber insert has to be checked with a template (ROTAX 277390). The crack of light between the template and the profile of the combustion chamber insert must be the same over the whole profile.

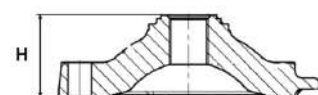

1.3. Piston with ring assembly

Original, coated, aluminium, cast piston with one piston ring. The piston has to show on the inside the cast wording "ELKO" (1) and "MADE IN AUSTRIA" (2).

Machined areas are: Top end of piston, outside diameter, groove for the piston ring, bore for the piston pin, inside diameter at bottom end of piston and some pre-existing factory removal (3) of flashing at the cut out of the piston skirt. All other surfaces are not machined and have cast surface.

Any mechanical treatment or rework of the piston is forbidden, (Altering the pistons profile by reworking carbon build-up is forbidden, if carbon is removed it must be consistently removed across the entire surface without altering the profile of the piston itself).

Example, selectively removing carbon in the squish measurement areas is forbidden.

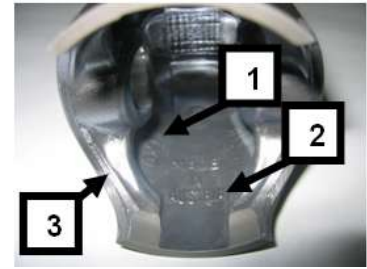

Original, magnetic, rectangular piston ring.

Ring height: 0,98 +/- 0,02 mm.

Piston ring is marked either with "ROTAX 215547", "ROTAX 215548", "ROTAX 215548 X" or "I ROTAX 215548 X".

The piston ring is legal also if just parts of the marking are still visible.

1.4. Piston pin

Piston pin is made out of magnetic steel.

Dimensions must be according to the drawing.

The minimum weight of the piston pin must not be lower than 31,00 grams.

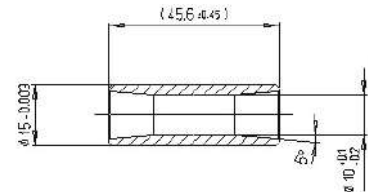

1.5. Cylinder

Light-alloy-cylinder with GILNISIL-plating.

Any re-plating of cylinder is not allowed.

Maximum bore of cylinder = 54,035 mm (measured 10 mm above the exhaust port).

1.5.1. Cylinder has to be marked with the "ROTAX" logo (see pictures below).

125 Micro MAX, 125 Mini MAX and 125 Junior MAX:

Cylinder with one main exhaust port and without exhaust valve.

Cylinders marked with identification code 223994 only are legal to be used.



125 Senior MAX:

Cylinder with one main exhaust port and exhaust valve.

Cylinders marked (cast or machined) with identification code 223993 only are legal to be used.



125 MAX DD2:

Cylinder with one main exhaust port and two side exhaust ports and exhaust valve.

Cylinder has to be marked with identification code 613933.



1.5.2. Height of cylinder

Measured with a digital calliper min. length 200 mm.



125 Micro MAX, 125 Mini MAX:	87,00 mm -0,05/+0,1 mm
125 Junior MAX, 125 Senior MAX:	87,00 mm -0,05/+0,1 mm
125 MAX DD2:	86,70 mm -0,05/+0,1 mm

1.5.3. Cylinder surfaces

All transfer ports and passages have cast finish surface except some removal (done by the manufacturer) of cast burr at the inlet passage, exhaust port and passages. All ports have chamfered edges to prevent ring snagging. Any additional machining is not permitted. The top edge of exhaust port may show some pre-existing machining from the manufacturer. The sealing flange for the exhaust socket may show signs of machining from the manufacturer.

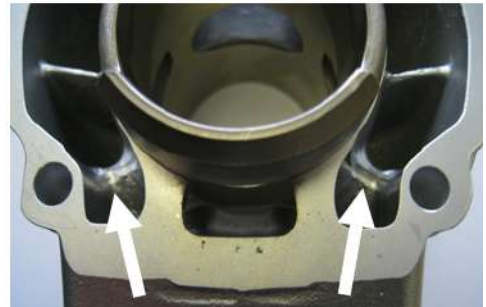

All ports have chamfered edges. Any additional machining is not permitted.



Cylinders marked 223993, 223994 and 613933 the upper edge of the central boost port may show factory machining.



The flange for the exhaust socket may show either cast finish or machined surface. Machined surface can be either flat or show a circular sealing bump.

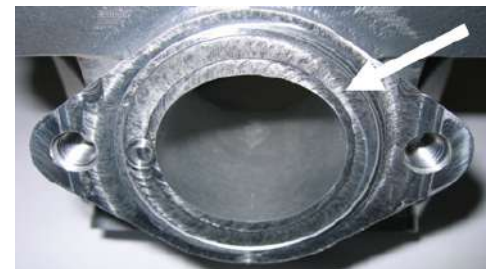

The top edge of the exhaust port may show either just a cast finish surface (left picture) or signs of a CNC machining (central picture) or signs of CNC machining in combination with signs of manual grinding (right picture).



The exhaust port may show partial manual grinding done by the manufacturer to

REGULATION

GLOBAL RMC Technical Regulation



eliminate minor casting defects and/or to eliminate the NIKASIL burr at the end of the NIKASIL plating (see above right picture).

Single Core Cylinder:

Cylinders marked 223994 and 223993 may show in the inlet port a linear texture. Cylinders marked 223994 and 223993 with linear texture in the inlet port show a fully CNC machined exhaust port and a fully CNC machined top edge of the central boost port.

Cylinders marked 613933 may show in the inlet port a linear texture.

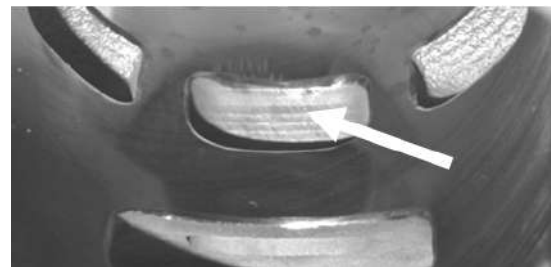
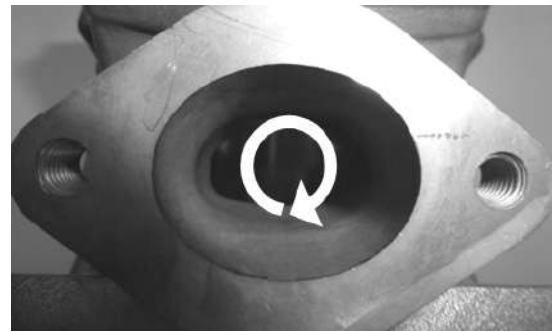
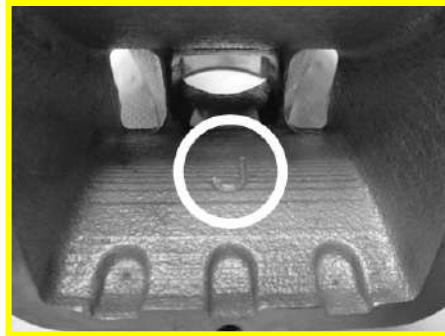

Single Core Cylinder:
linear structured cast finish surface

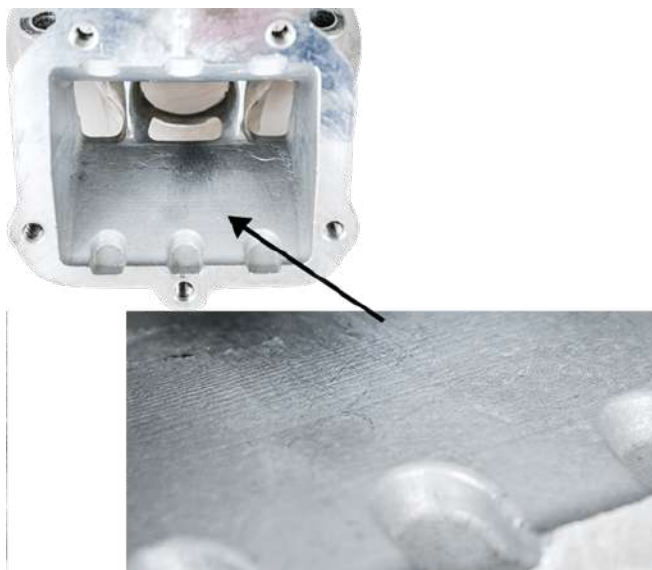

1.5.4. Exhaust port shape

Cylinder 223994 with fully CNC machined exhaust port only:

The horizontal and vertical dimensions of the exhaust port have to be checked with the template, Rotax 676240.

Cylinder 223993 with fully CNC machined exhaust port only

The horizontal and vertical dimensions of the exhaust port have to be checked with the template, marked with 676245*.



The template has to be moved in horizontal and vertical position as far as possible into the exhaust port.

In both directions, the template may not touch the flange for the exhaust socket.



1.5.5. Exhaust port timing

The "exhaust port timing" (distance from the top of the cylinder to the top of the exhaust port) has to be checked by means of the template (ROTAX 277402).

Insert the template into the cylinder, and move the template (at the highest point of the exhaust port) as far as possible into the exhaust port.

In this position the template may not touch the cylinder wall.



Take care to use the correct gauge for:

- Junior MAX (Junior template to be used for Micro MAX and Mini MAX)
- Senior MAX
- MAX DD2

1.6. Inlet system

1.6.1. Reed valve assy.

The reed valve assy. is equipped with 2 petal stops and 2 reeds, each having 3 petals.

The thickness of the reeds is 0,6 mm +/- 0,10 mm.

1.6.2. Inlet manifold

Some factory flash removal may be present at the conjunction of the inside contour and the carburettor stop mounting face. This is a manual trimming operation consisting of a small corner break of less than 3 mm in width. No additional grinding or machining is permitted.

125 Micro MAX, 125 Mini MAX, 125 Junior MAX and 125 Senior MAX:

Inlet manifold marked with the identification code "267915" and the name "ROTAX" or just "267916".

125 MAX DD2:

Inlet manifold marked with the identification code "267410" and the name "ROTAX" or just "267411".



1.7. Crankshaft

1.7.1. Con rod

Stroke 54,5 mm +/-0,1 mm

Con rod has to show forged numbers "213", "365", "367" or "362" on shaft.

Shafts of con rods "213", "365" and "367" are not machined and are copper plated.

Shaft of con rod "362" is not copper plated and is blank (grey/brown).

Grinding or polishing of shaft of con rod is not permitted.



1.7.2. Ignition signal on crankshaft

Fit the template (Rotax 277391) on the crankshaft.
Align the hole in the template for the big end pin with the big end pin of the crankshaft.
The two edges of the signal machining on the crankshaft must be in line ($\pm 0,5$ mm) with the corresponding edges (MAX or DD2) of the template.



1.7.3. Crankshaft main bearings

Crankshaft main bearing 6206 from FAG is allowed only.
(must be marked with code 579165BA or Z-579165.11.KL)

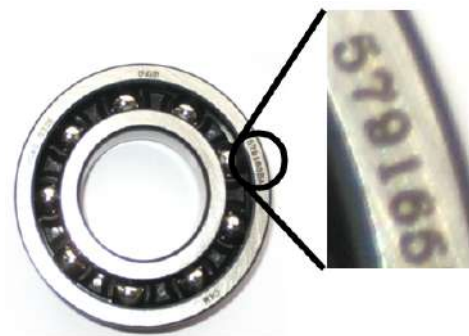

1.8. Balance Shaft

Balance shaft and balance gears must be installed.

125 Micro MAX, 125 Mini MAX, 125 Junior MAX and 125 Senior MAX:

Balance shaft must show casting code 6237948 or 6237949 on surface (1).
Surface (1) is not machined and must show cast surface.
The minimum weigh of the dry balance shaft must not be lower than: 255 grams.

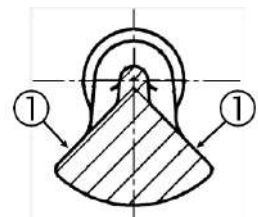

1.9. 2-speed gearbox (for 125 MAX DD2 only)

Primary shaft with 19 teeth for 1st gear and 24 teeth for 2nd gear.
Idle gear for 1st gear has to have 81 teeth.
Idle gear for 2nd gear has to have 77 teeth

1.10. Crankcase

As supplied by the manufacturer.
No grinding/polishing is permitted in the two main transfer passages as well as in the crank area.
For the Rotax Nordic Challenge events only black coated crankcases are legal to be used. For National RMCs in Estonia, Latvia and Lithuania at 2021 uncoated or black coated crankcases are legal to be used. Starting from 2022 on all RMC events only black coated crankcases are legal to be used.

2. Technical Specification outside the engine seal for Rotax MAX kart engines

It is the responsibility of the competitor to check his equipment (all components outside the engine seal as mentioned below), to assure that his equipment is conforming to the technical specification below!

2.1. Balance drive

125 Micro MAX, 125 Mini MAX, 125 Junior MAX and 125 Senior MAX:

Steel balance gears only (minimum width = 8,8 mm) are legal to be used.

Balance gears must be installed and must be aligned according to the instruction in the repair manual.

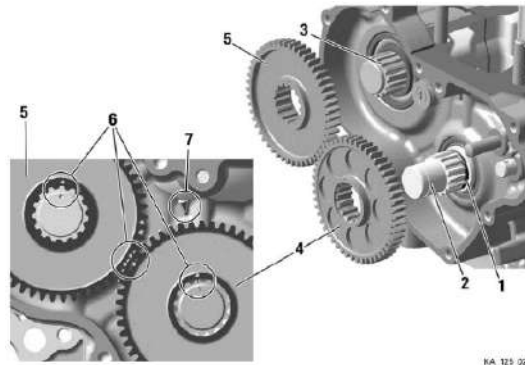

125 MAX DD2:

Balance drive gear must be fitted on crank shaft.

Balance gear must be fitted on primary shaft and must be aligned with the balance drive gear according to the instruction in the repair manual.

Version 1:

Fly weight of balance gear must show cast surface



Version 2:

Fly weight of balance gear can show machined surface.

Dimension A (widest part of balance weight) must be either

53,0 mm +/- 0,5 or 57,0 mm +/- 0,5

The minimum weight of a dry balance gear including bearing must not be lower than 240 grams.



Version 3:

ROTAX part number 635745 (visible on the gear)

Fly weight of balance gear can show machined surface.

The minimum weight of a dry balance gear including bearing must not be lower than 255,0 grams.

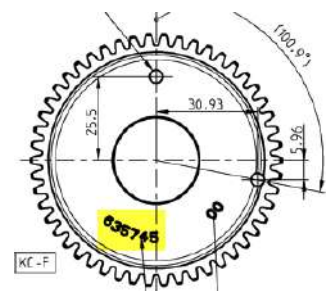

2.2. Centrifugal clutch

2.2.1. Components

125 Micro MAX, 125 Mini MAX, 125 Junior MAX and 125 Senior MAX:

Engagement speed of centrifugal clutch at maximum 4.000 rpm (the kart without driver must start to move). Two versions of clutch (item 1, with and without holes)

are legal to be used.

Both versions are marked with the wording "ROTAX".

O-ring (item 2) must be fitted and must assure an appropriate sealing between the clutch drum and the needle/plain bearing.

Two versions of clutch drum (item 3) are legal to be used. Both versions are marked with the wording "ROTAX".

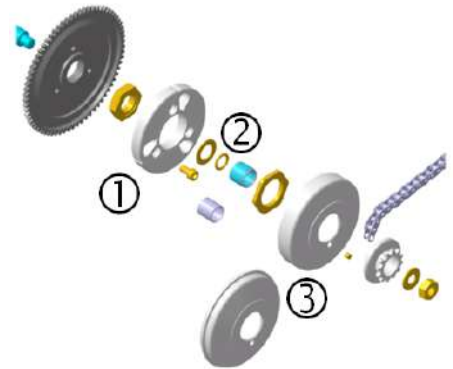

Signs of emission of grease or substance from the needle/plain bearing into the clutch drum may not exceed the picture beside.

Contact area between clutch and clutch drum has to be dry at any time – no lubrication allowed.



125 MAX DD2:

Engagement speed of centrifugal clutch at maximum 4.000 rpm (the kart without driver must start to move).

Both versions of clutch (item 6, with and without holes) are legal to be used.

O-ring (item 11) must be fitted.

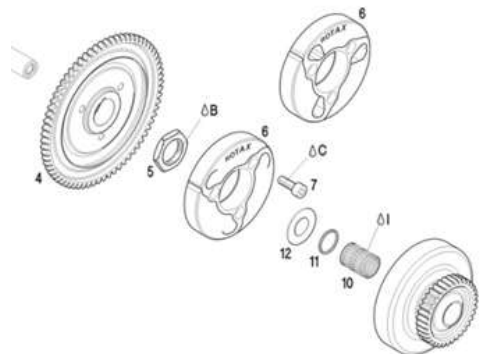

2.2.2. Clutch dimensions

Thickness of clutch shoe (A):

All MAX Engines Minimum = 24,10 mm

Measurement must be done at the 3 open ends of the clutch, 5 - 10 mm from the machined groove (all clutch shoes must be completely closed at measurement - no gap).



Height of clutch (B):

125 Micro MAX, 125 Mini MAX, 125 Junior MAX and 125 Senior MAX: Minimum = 11,45 mm

125 MAX DD2: Minimum = 14,45 mm

Clutch drum Outer diameter (C):

Minimum = 89,50 mm
Diameter must be measured with a sliding calliper just beside the radius from the shoulder (not at the open end of the clutch drum).

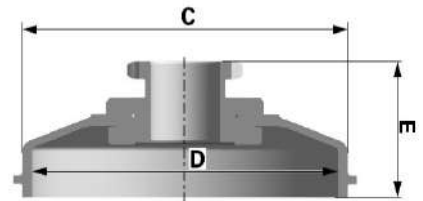

Clutch drum Inner diameter (D):

Maximum = 84,90 mm
Diameter must be measured with a sliding calliper. The measurement must be done in the middle of the clutch drum (in the contact area between clutch and clutch drum).

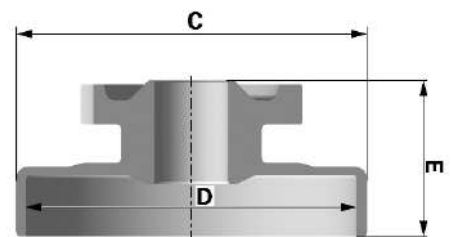

Clutch drum Height (E) with sprocket/primary gear

125 Micro MAX, 125 Mini MAX, 125 Junior MAX, 125 Senior MAX: Minimum = 33,90 mm

125 MAX DD2: Minimum = 39,50 mm

2.3. Primary drive (125 MAX DD2):

Original primary drive gears (4+5) of following gear ratio options must be used only.

Following combinations are legal to be used.

Drive gear	Driven gear
32	65
33	64
34	63
35	62
36	61
37	60
38	59

A specific primary gear ratio may be determined for each race event by a "Bulletin".

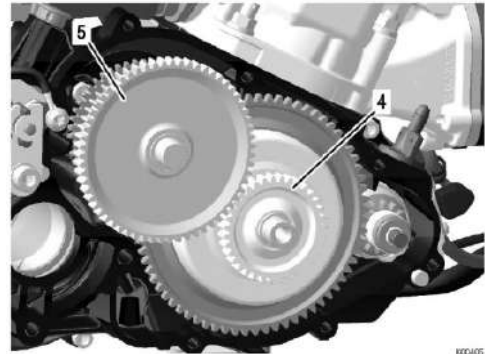

2.4. Gear shifting (125 MAX DD2)

The 2-speed gearbox must be operated from the steering wheel via the original Rotax paddle shift system (see illustration). Cutting of the original aluminium shift paddles (30) or adding of non-original parts is not allowed.

Mounting the shift paddles (30) on the bottom or top side of the whip (23) is an allowed adjustment.

Optional parts (35-37) can be mounted on the shift paddle (30) in any position.

Bending the aluminium shift paddles to align them to the steering wheel is an allowed adjustment.

The whip (23) offers two connections for the cables (23) on each side for short travel or long travel. Both connections are legal to be used.

To change the connections of the cables to the whip (23) from left to right and right to left is an allowed adjustment

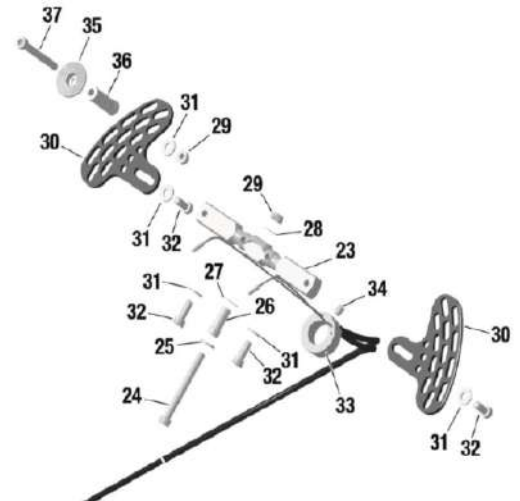

2.5. Combination of ignition system, carburettor and exhaust system

The combination of components is limited to following specification per engine type.

Component \ MAX Engine	Micro Mini	Junior	Senior	DD2
Ignition system Dell'orto	✓	✓	✓	✓
Exhaust valve, electronic timed	-	-	✓	✓
Carburettor XS	✓	✓	✓	✓
Exhaust system, evo	✓	✓	✓	✓

2.6. Exhaust valve (125 Senior MAX and 125 MAX DD2)

System must be used with all components fitted as shown in the illustration below.

Bellow (8) must have green colour.

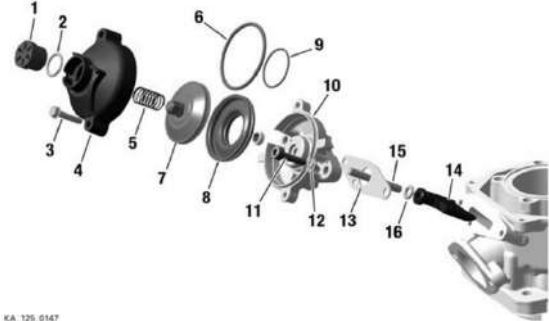

KA_125_0147

2.6.1. Exhaust valve

Length of the exhaust valve (item 2):
36,5 mm $+0,20$ mm/ $-0,30$ mm.

Width of collar:
4,8 mm $+/-0,3$ mm

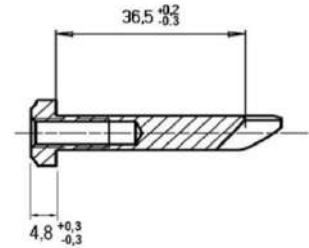

2.6.2. Distance of exhaust valve flange at cylinder to piston

Turn crankshaft until the piston just closes the exhaust port.

Insert the exhaust valve gauge (Rotax 277030) as shown in the picture until it stops at the flange.

At the circular contact area between exhaust valve and the flange of the cylinder, a feeler gauge 0,25 mm may not fit between the gauge and the flange.

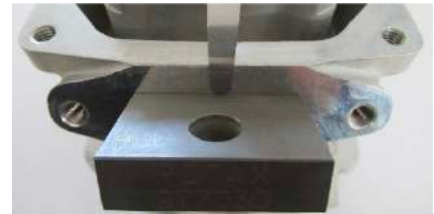

2.6.3. Impulse nozzle:

Fitting an original impulse nozzle ❶ into the pressure hose is an allowed adjustment.

The direction of the impulse nozzle inside the pressure hose is free.

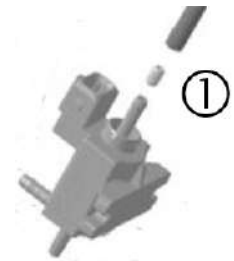

2.6.4. Exhaust valve settings

The electronic timed exhaust valve offers two different settings (A or B) for the opening of the exhaust valve.

(A)...additional ground cable not connected
(B)...additional ground cable connected

Both settings are legal to be used.

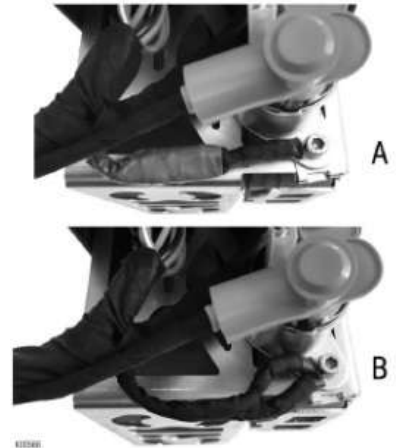

2.7. Ignition system

Digital battery ignition system, variable ignition timing, no adjustments possible.

2.7.1. Spark plug

125 Micro MAX and 125 Mini MAX:

Spark plug: NGK GR8DI or NGK GR9DI
Electrode gap (maximum): Filler gauge 1,20 mm must not fit in between the two electrodes.

125 Junior MAX, 125 Senior MAX:

Spark plug: NGK GR8DI or NGK GR9DI
Electrode gap (maximum): Filler gauge 1,00 mm must not fit in between the two electrodes.

For the 125 MAX DD2:

Spark plug: NGK GR8DI or NGK GR9DI
Electrode gap (maximum): Filler gauge 1,00 mm must not fit in between the two electrodes.

2.7.2. Spark plug caps

One version of the spark plug cap is legal to be used.

Red, marked NGK. ROTAX 866707



Version 1.

2.7.3. Pick-up

The marking of the pick-up must show the following numbers in the first line 029600-0710. A steel ball (diameter 3-5 mm) placed on circular surface of the sensor must stay in the center of the circular surface.



Mounting the pick-up to the crankcase with a gasket additional to the original rubber sealing ring of the pick-up, is a legal specification.

Additional gasket, Rotax 431500, gasket thickness = 0,8 mm Maximum two gaskets (Rotax 431500) are allowed to be fitted.

Fitting position of the additional gasket(s):
Crankcase – rubber sealing ring –
additional gasket(s) – pick-up.

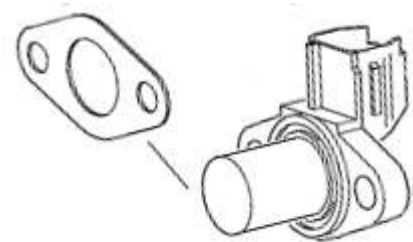

Note: It is not necessary to install any additional gasket/s with the exception of the rubber sealing ring on crankcases with the machined sealing surface for the pick-up sensor.

2.7.4. Ignition System

Dellorto ignition system is legal to be used only.

Race officials may request at any time that the competitor replaces the electronic box (ECU) with another unit provided by the race administration.

The visual appearance of the ignition coil must be identical with the pictures. Ignition coil must show 2 pins at the terminal. The ignition coil is labelled with two stickers, "BRP 666820" and "NIG 0105". The ignition coil is still legal to be used also if one or both stickers disappeared. Minimum length of the high tension cable of the ignition coil is 210 mm (from outlet of ignition coil to outlet of spark plug connector = visible length of cable).



Ignition coil (same for all engines) with separate electronic box (ECU, specific for every engine). Ignition coil and ECU (and magnet valve, for 125 Senior MAX and 125 MAX DD2 only) must be fitted with all components according to the illustrations below.

125 Micro MAX, 125 Mini MAX, 125 Junior MAX and 125 Senior MAX:

In case the mounting bracket (125 Micro MAX, 125 Mini Max, 125 Junior MAX and 125 Senior MAX only) is in conflict with a chassis component, the additions of 2 spacers, one per mounting hole, with a maximum thickness of 20 mm between the mounting bracket and the gearbox cover is allowed.



125 DD2 MAX / Masters: The electrical contact at the shift assembly must be connected, as per the picture below.

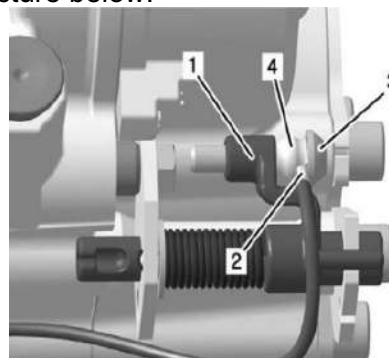

125 MAX DD2:

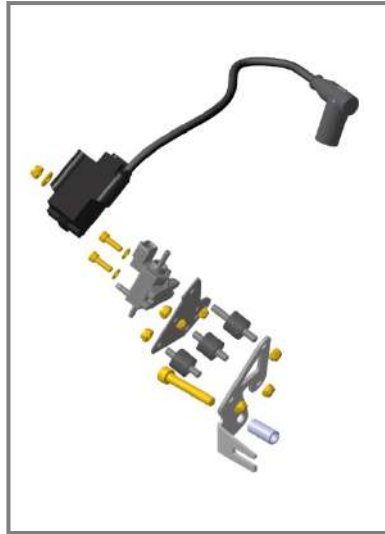

2.7.5. ECU

The electronic control unit (ECU) is labelled with stickers and is still legal also if the sticker is unreadable or disappeared.

125 Micro MAX:	"666815"
125 Mini MAX:	"666818"
125 Junior MAX:	"666813"
125 Senior MAX:	"666815"
125 MAX DD2:	"666816"

The ECU must be checked with the ECU tester (Rotax 276230) according to following procedure.

Disconnect engine cable harness from ECU.

Connect ECU tester cable harness to ECU.

Connect energy cable of ECU tester cable harness with the charging connector of engine cable harness.

At every connection with the battery the software version of the ECU tester will be indicated on the display for approx. 2 seconds.

The software version indicated on the display must be 2V00.

Start the test by pressing the button "✓" on the ECU tester.

After approx. 3 second the type of ECU ① that is actually tested will be indicated in the second line of the display.

After approx. 30 seconds the result ② of the test will be indicated in the first line of the display.



The ECU tester must indicate following results:

125 Micro MAX category

- ① 666815MAX
- ② !! Test OK !!

125 Mini MAX category

- ① 666818MINIMAX
- ② !! Test OK !!

125 Junior MAX category

- ① 666813JNRMAX
- ② !! Test OK !!

125 Senior MAX category

- ① 666815MAX
- ② !! Test OK !!

125 MAX DD2 category

- ① 666816MAXDD2
- ② !! Test OK !!



2.8. Battery, battery fixation and wiring harness

Original batteries with following specification only are legal to be used.

YUASA YT7B-BS (with and without Rotax branding)

ROTAX RX7-12B or RX7-12L (lithium iron phosphate type)

Battery must be fitted with an original battery clamp and battery cover (according to illustrations) and must be fixed to the chassis with both clamps (all 4 screws). Battery clamp with or without cable support is legal for use.

Battery clamp must be mounted on the left side of the Chassis, next to the seat.

When using the more flexible wiring harness (part no. 666 836), it is mandatory to use the battery holder including the cable support (part no. 251 129).

See the figure right to see how the wiring harness must be installed to the battery holder. The correct installation of the wiring harness ensures that the connections between the battery holder and the wiring harness is not under stress.

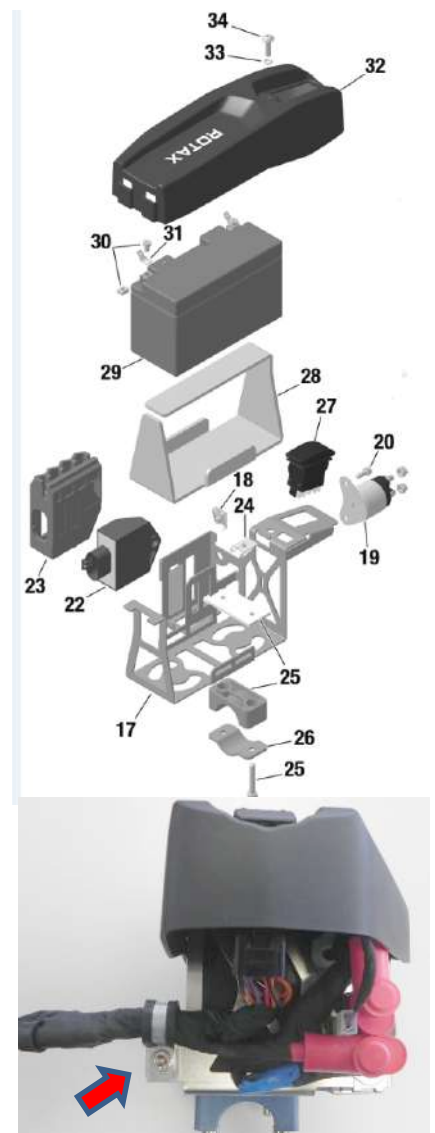

REGULATION

GLOBAL RMC Technical Regulation



Two versions of the wire harness are allowed to be used.

The differences between the two versions can easily be identified by the key points listed.

Wiring Harness (666 835)

Wiring Harness (666 836)

ECU Connector

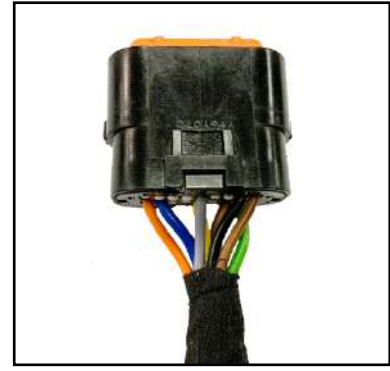

Charging Connector



Solenoid Connector

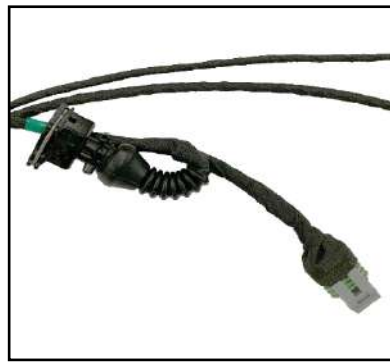

2.9. Intake silencer

125 Micro MAX , 125 Mini MAX, 125 Junior MAX and 125 Senior MAX

Intake silencer with integrated, washable air filter must be used with all parts as shown at the illustration and has to be mounted on the support bracket with two screws (in dry and wet condition).

Intake silencer tube (pos 2) and carburettor socket (pos 6) are marked with the wording "ROTAX".

Intake silencer case bottom is marked on the inside with "225015".

Intake silencer case, top is marked on the inside with "225025".

Two versions of original air filters (pos.4) are legal to be used.

Double layer air filter (green/orange), double layer air filter (green/dark green) marked "Twin Air". Depending on the degree of oil-lubrication colours may alter slightly or the surface becomes stained (see examples).

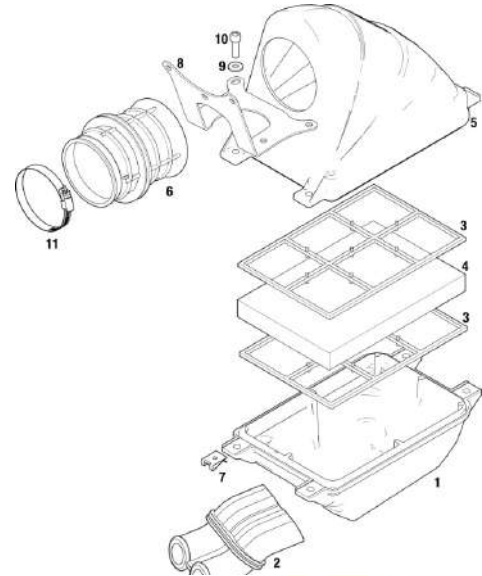

Air filter (pos 4) must be installed as shown in the illustration between the two holders (pos 3) and must cover the complete area of the intake silencer case bottom (pos1).

Pos. 4, legal air filter executions

During wet condition, it is not allowed to attach anything to the air box to protect the air inlet from water spray.

125 MAX DD2:

Intake silencer with integrated washable air filter as shown in illustration.
The intake silencer case (pos 1) is marked on the inside with "225012" (4 clips) or "225013" (5 clips).

The intake silencer cover (pos 2) is marked on the inside with "225022" (4 clips) or "225023" (5 clips).

Two versions of air filters (pos 3) are legal to be used.

Version 1, with integrated steel frame.

Version 2, with separate plastic frame (pos 4).

The air filter must be assembled between the intake silencer case and the intake silencer cover that the whole area of the intake silencer case is covered.

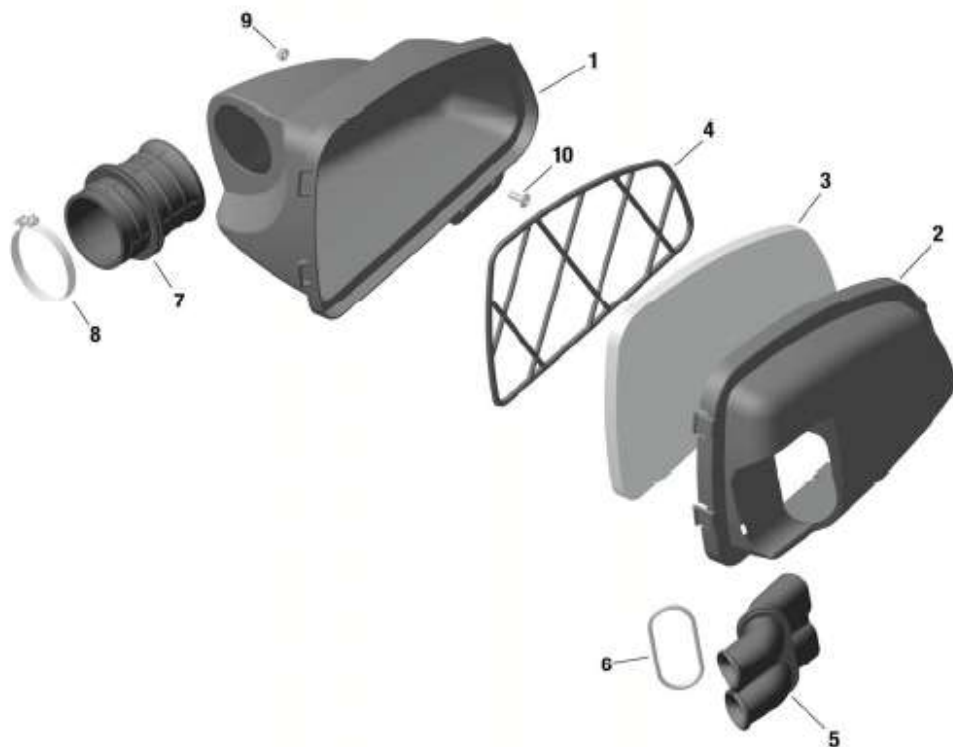

At intake silencer cover (pos. 2, Rotax 225022), it is mandatory to fit the O-ring (pos. 6) on the intake silencer tube (pos. 5). Intake silencer tube (pos 5) and carburettor socket (pos 7) are marked with the wording "ROTAX".

Sealing the top of the intake silencer using adhesive tape is an allowed modification.

During wet condition, it is not allowed to attach anything to the air box to protect the air inlet from water spray.

2.10. Carburettor

Dellorto carburettor, housing must show the cast wording "VHSB 34"

Carburettor housing is stamped with "XS".

The complete inlet bore of the carburettor must show cast surface.

Optional carburettor plug screw marked "ROTAX" (ROTAX part no. 261 030) is legal to be used.

The two vent fittings must be connected with the original air vent hose min 155 mm (Rotax 260260). The location of the opening has to be placed at the rear side of the carburettor

Settings of the carburettor adjustment screws (idle and idle air) are free.

The position of the jet needle is free.

All jets must be correctly seated and securely fitted at any time (tightened)!

A minimum required size of main jet may be determined for each race event by a "Bulletin".

The complete inlet bore of the carburettor housing must show cast surface.

The venturi hole of the carburettor insert can show signs of a CNC control machining.

Carburettor can be used with and without fuel sieve in the carburettor housing.

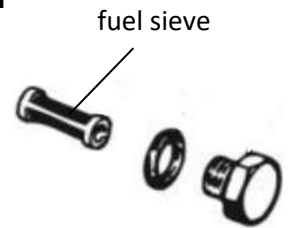
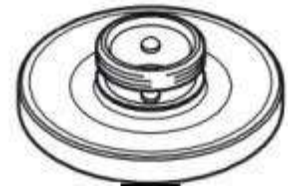

The height of the two arms of the float lever must be within the slot of the carburettor gauge (Rotax 277400) by their normal weight measured at carburettor housing without gasket in reverse upright position.



Needle valve assembly stamped "150"

Needle of needle valve marked with diamond symbol "INC" only.



Start jet is stamped with the digits "60".

Any Dellorto main jet number even if not offered from Rotax is legal to be used.

REGULATION

GLOBAL RMC Technical Regulation



Carburettor slide shows digits "45" in casting.

Jet needle must be stamped with "K57".

Two floats marked "4,0 gr" are legal to be used only

Needle jet
Stamped with "DP267"
Total length: 51,0 +/- 0,5 mm



Length of bottom section: 33,0 +/- 0,45 mm



Top bore diameter 2,67 +/- 0,10 mm



Idle jet
Idle jet has to be stamped with 60.
Plug gauge 0,65 mm may not enter the bore
(use jet gauge set Rotax part no. 281 920).



Idle emulsion tube
Idle emulsion tube has to be stamped with 45.
Plug gauge 0,50 may not enter the central bore.
(use jet gauge set Rotax part no. 281 920)



REGULATION

Atomizer
Remove atomizer from carburettor body by means of
of
venturi tool set (Rotax part no. 676 034);
Atomizer, total length: 23,75 +/- 0.35 mm



Atomizer, length of cylindrical part:
15,75 +/- 0,25 mm



Atomizer, dimension of cutaway: 5,8 +/- 0,3 mm



Atomizer, dimension of cross bore: 5,0 +/- 0,15 mm



REGULATION

GLOBAL RMC Technical Regulation

Carburettor insert must show stamping "12,5"



Angular bore of carburettor insert
Plug gauge 0,60 may not enter the bore
(use jet gauge set Rotax part no. 281 920).



Vertical bore of carburettor insert
Plug gauge 1,30 may not enter the bore
(use jet gauge set Rotax part no. 281 920).



125 Micro MAX and Mini MAX:

The throttle body restrictor must be installed in the rear of the carburettor and in the correct orientation at all times (see picture 1 below for reference).

ROTAX part number: 267536

No modifications are allowed, the ribbed surface on the inlet is to help ensure dimensions have not been modified.

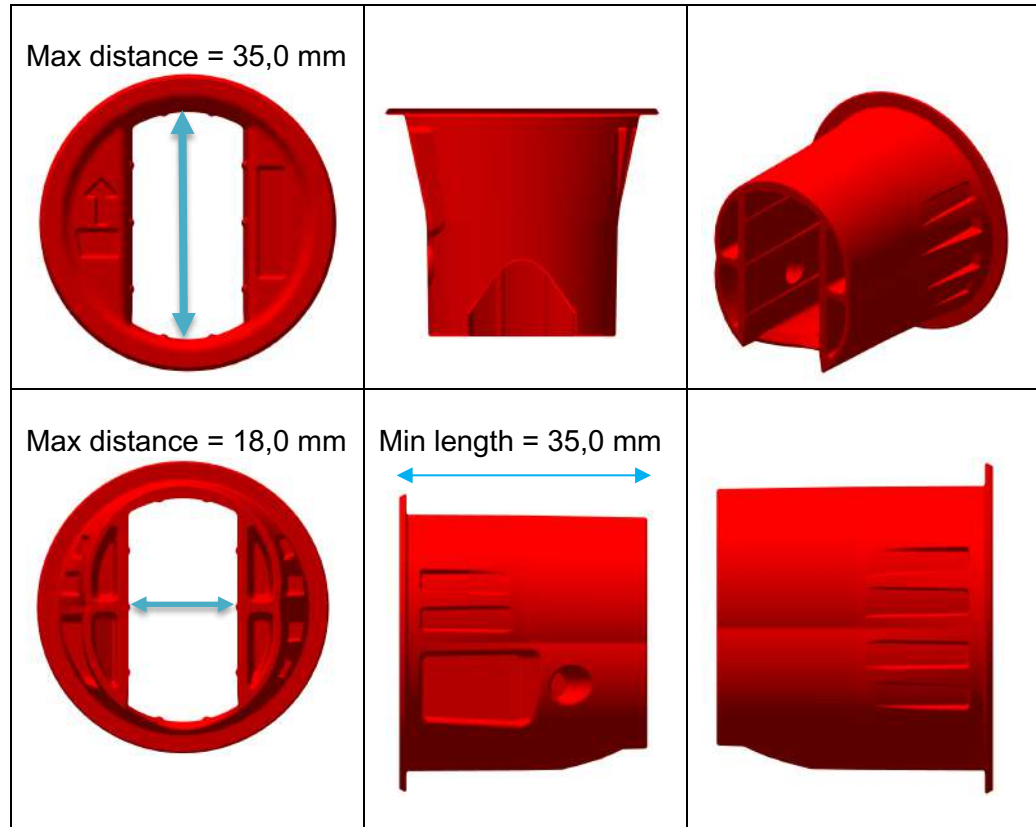

Picture 1.



2.11. Fuel pump, fuel filter

MIKUNI diaphragm pump, (see picture) must be used and must be mounted as shown in the illustration.



125 Micro MAX, 125 Mini MAX, 125 Junior MAX and 125 Senior MAX:

Fuel pump must be mounted on the bottom side of the support bracket for the intake silencer (left illustration).

125 MAX DD2:

Fuel pump must be mounted on the support bracket, marked 651055 or 651056, attached to the clutch cover (right illustration). Mounting the fuel pump with the two original rubber buffers to the chassis is an allowed option. In this case the fuel pump must be mounted below the inlet center line of the carburettor.

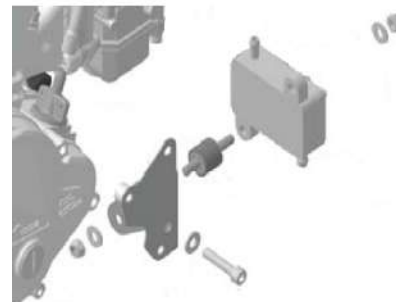
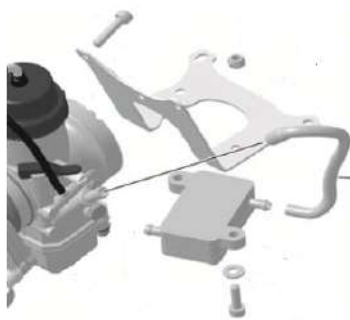

2.12. Fuel filter

Two versions of original fuel filter are legal to be used (see pictures). The fuel filter must be mounted between the fuel tank and the fuel pump. Except the fuel line, the fuel pump and the original fuel filter no additional parts are legal to be mounted between fuel tank and carburettor.



2.13. Radiator

The removal of the thermostat from the cylinder head cover is an allowed modification.

Radiator must be mounted with all components as shown in the respective illustration.

To apply tape (neutral tape without advertising only) around the radiator is an allowed modification to control the air flow through the radiator.

Tape may not be removed from the radiator during operation on the track. Any other non-original device to control the air flow through the radiator is prohibited.

125 Micro MAX and 125 Mini MAX:

Two different versions as shown in the illustrations are legal to be used.

Cooling area:
 Height: 280 – 300 mm
 Width: 58 – 62 mm
 Thickness of radiator: 30 – 34 mm

To remove the original flap is an allowed modification.

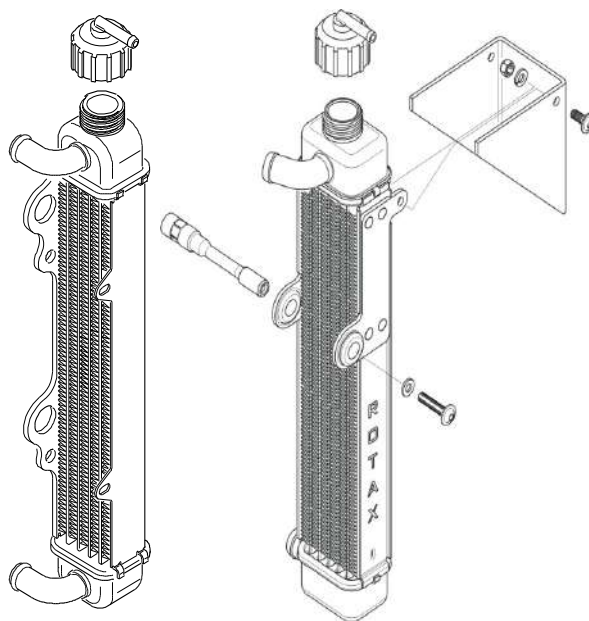

125 Junior MAX and 125 Senior MAX:

The radiator must be mounted on the right side of the engine. Three different versions as shown in the illustrations are legal to be used.

Version 1

Cooling area:
 Height: 290 mm
 Width: 133 mm
 Thickness of radiator: 32 mm

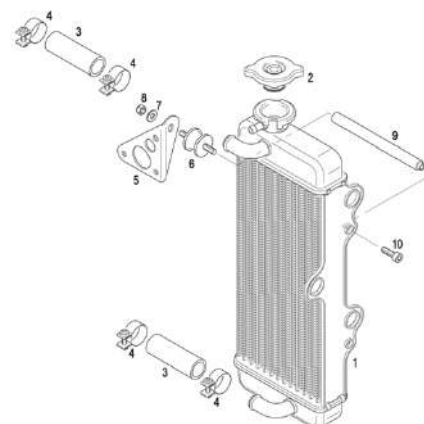

Version 2

Cooling area:
Height: 290 mm
Width: 133 mm
Thickness of radiator: 32 mm

The support plate (pos. 7) enables two different mounting positions (height) of the radiator. Both mounting positions are legal to be used.

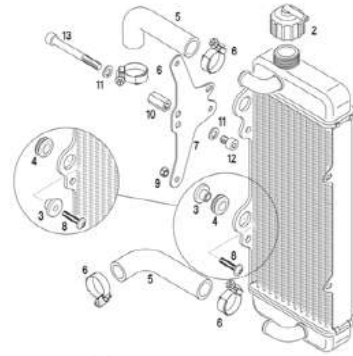

Version 3

Cooling area:
Height: 290 mm
Width: 138 mm
Thickness of radiator: 34 mm

Radiator must be stamped on the side with the wording "ROTAX".
To remove the original flap is an allowed modification.

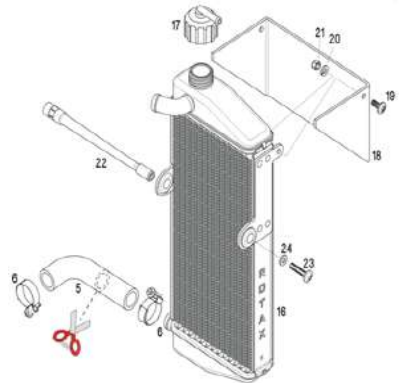

125 MAX DD2:

The radiator has to be mounted on the left side of the driver seat.
The highest point of the radiator with cap may not be higher than 400 mm above the main tube of the kart chassis.
Two different versions as shown in the illustrations are legal to be used.

Version 1

Cooling area:
Height: 284 mm
Width: 202 mm
Thickness of radiator: 32 mm

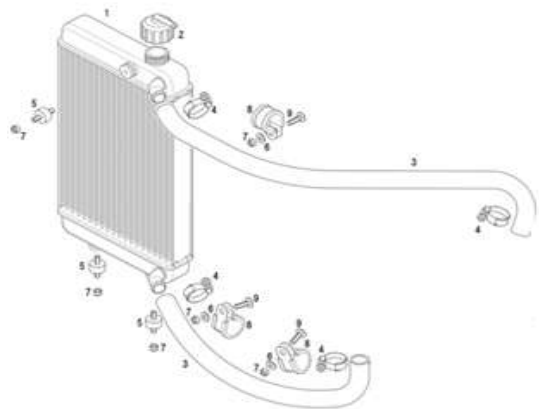

Version 2

Cooling area:
Height: 290 mm
Width: 196 mm
Thickness of radiator: 34 mm

To remove the original flap is an allowed modification.

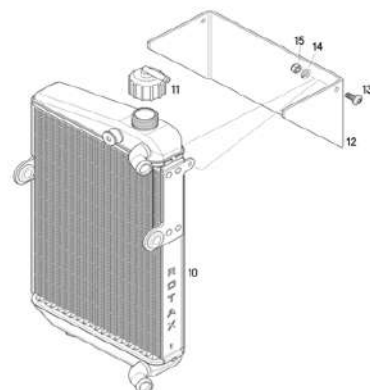

2.14. Engine coolant

Plain water without any additives has to be used.

2.15. Exhaust socket (Restrictor)

125 Micro MAX and 125 Mini MAX :

Just exhaust sockets with gasket ring are legal to be used.

Diameter (A) must apply for a length (B) of at least 12 mm.

Maximum inner diameter (A) of exhaust sockets are:

125 Micro MAX: 18,20 mm (Rotax part no. 273 192)

125 Mini MAX: 22,20 mm (Rotax part no. 273 196)

The measurement (C) must be at least 18,5 mm.

The internal profile of the exhaust socket has to be checked with the template, Rotax 277 405.

Fit the template (**125 Micro MAX** "18 mm", **125 Mini MAX** "22 mm") as far as possible into the exhaust socket (without gasket, carbon deposits removed). There has to be a constant crack light between the profile of the exhaust socket and the profile of the template.

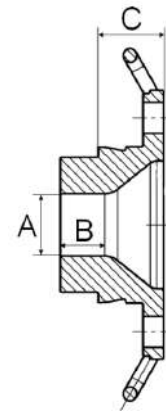

125 Junior MAX, 125 Senior MAX, 125 MAX DD2:

Only Rotax part no. 273 190 is allowed to be used.

The measurement (C) must be at least 15,5 mm.



2.16. Exhaust system

The use of maximum 4 pieces of original Rotax exhaust springs, to fix the exhaust system to the cylinder is allowed.
(a “safety wire” in the exhaust flange area is not allowed).

Original exhaust system as supplied by Rotax is mandatory to be used for the relevant class.

Welding at the exhaust system is only allowed in the case of a repair.

Allowed modifications on the original exhaust systems are:

- Replacing the original rivets of the silencer end cap by 4 mm metric screws and corresponding locking nuts.
- Replacing the isolating mat (just one original isolating mat may be fitted) inside the silencer and the silencer end cap with perforated tube by original Rotax spares parts.

125 Micro MAX	ROTAX part number 297982
125 Mini MAX	ROTAX part number 297985
125 JNR MAX	ROTAX part number 297982
125 SNR MAX	ROTAX part number 297982
125 DD2 MAX	ROTAX part number 297982

Note: For post-race technical scrutineering checks on the exhaust isolating mat, only the used weight is to be controlled.

The new size and weight specifications can only be applied for pre-race / event technical checks against new material prior to installation and sealing of the exhaust system, if specified by the event /series organizer.

- Welding a socket (in a distance of 50-80 mm from the ball joint) on the top of the exhaust system for measuring the exhaust gas temperature.
- Addition extra elements after the original silencer for further noise reduction.
- Additional to the standard isolation mat a steel isolation mat (Rotax part no. 297 983) with the square dimension of 165 +10 mm is legal for use in the JNR / SNR and DD2 category's only (not mandatory) to be assembled underneath the standard isolation mat according to the illustration.

Clamp (1) must be fitted at a distance of 18+/-2mm, measured from the end of the tube.

Clamp (2) must be fitted at the end area of the steel isolation mat.

The measurement 10-12 mm from the end of the perforated tube to the beginning of the steel isolating mat is a specification for assembly purpose only!

Both clamps (1 and 2) are mandatory to be fitted and tightened.

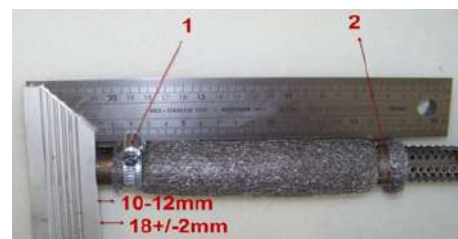

2.17. 125 Micro MAX:

A specific Exhaust system has to be used for the 125 Micro MAX engine.
 ROTAX Part number 273136

The Exhaust external body is a common component to Mini MAX, but with alternative internal components (Inserts).

The silencer must be mounted in a position where the direction of the 90° elbow outlet (direction of the hot exhaust gasses) does not harm any component of the chassis.

The measurements in the diagram below are as follows:

- (a) 580 mm +/- 5mm
- (b) 299 mm +/- 5mm
- (c) 42 mm +/- 3mm

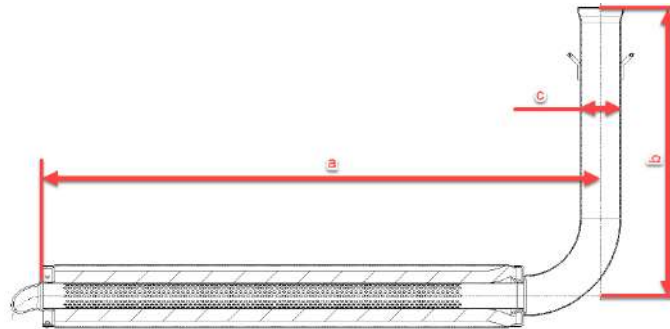

A steel ball with a 28.0mm diameter **must not** pass through Section "A" and a steel ball with a 26.0mm diameter must be able pass through Section "A" in the below diagram from the inlet and through the 90-degree elbow completely.
 (Internal exhaust components must first be removed)

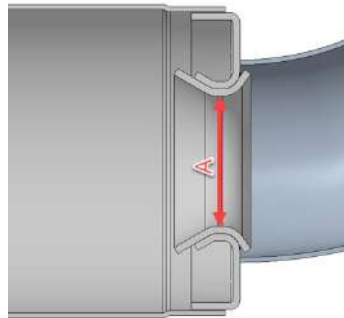

The inner measurement of the exhaust system silencer end (a) in the below diagram must be a maximum of 63.0 mm.

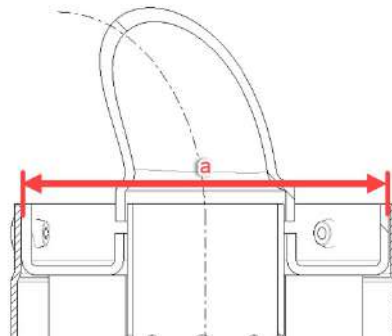

(Note: this is not a measurement of the perforated tube)

The Exhaust must be installed firmly to the chassis using a rigid mount/s.

The Exhaust must be mounted to the rigid mount/s using 2 ROTAX silent blocks. (part 660920 and or 260657 allowed).

The deflection of the 2 silent blocks is the only Exhaust movement allowed.

The Exhaust must be mounted in a neutral position with no stress on the 2 silent blocks.

125 Micro MAX Perforated tube

ROTAX part number: 273212

The measurements in the diagram below are as follows:

- (a) at least 498 mm
- (b) minimum outside diameter of 61mm
- (c) maximum outside diameter of 26mm
- (d) minimum length 63mm

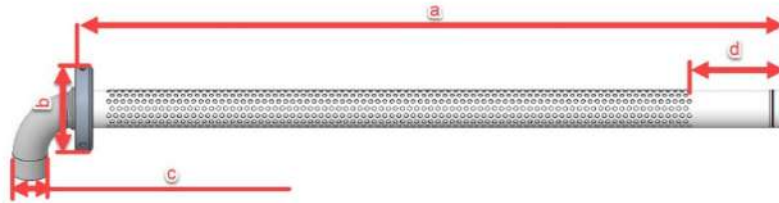

The measurements in the diagram below are as follows:

- (a) minimum outside diameter of 26.0mm



The only legal Isolation matting for 125 Micro MAX is:
ROTAX part number 297982

New size minimum 480 x 270mm (+/-10mm)

New weight 207gr (176g – 238g)

Used weight minimum 140g

Used weight maximum 300g

NOTE:

The only exhaust system allowed for racing in the 125 Micro and 125 Mini MAX category's is the MY2020 version.

The exhaust has 3 clear visual differences to identify the MY2020 version.

1. Exhaust hooks
2. Connecting socket / ball joint connect at manifold
3. Wall thickness of the exhaust system is 1.0mm (older exhaust system which is not allowed for racing has a wall thickness of 1.5mm)

REGULATION

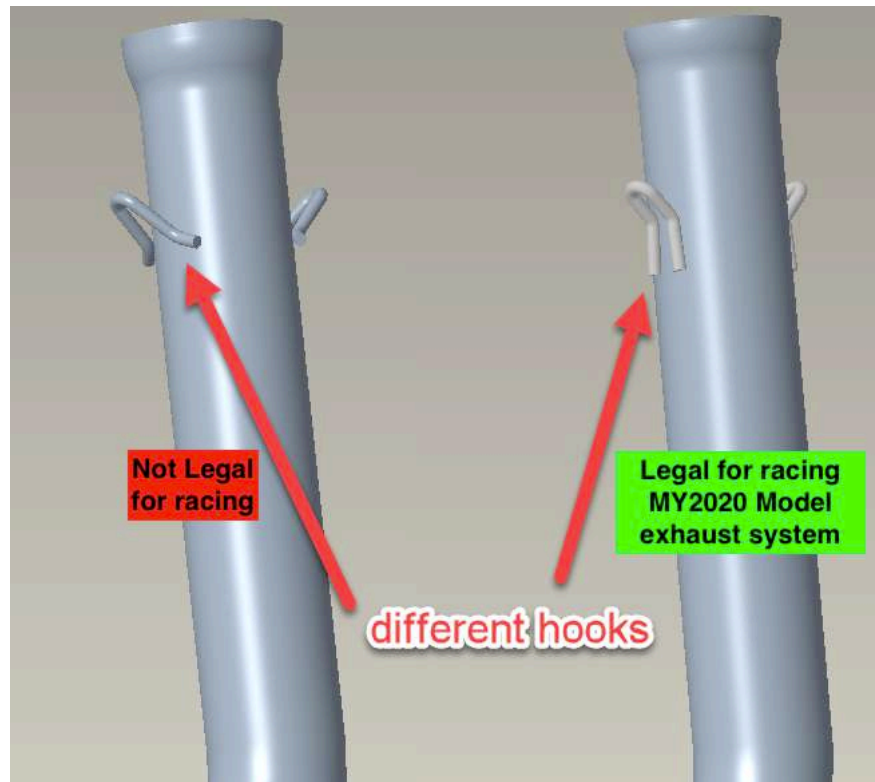
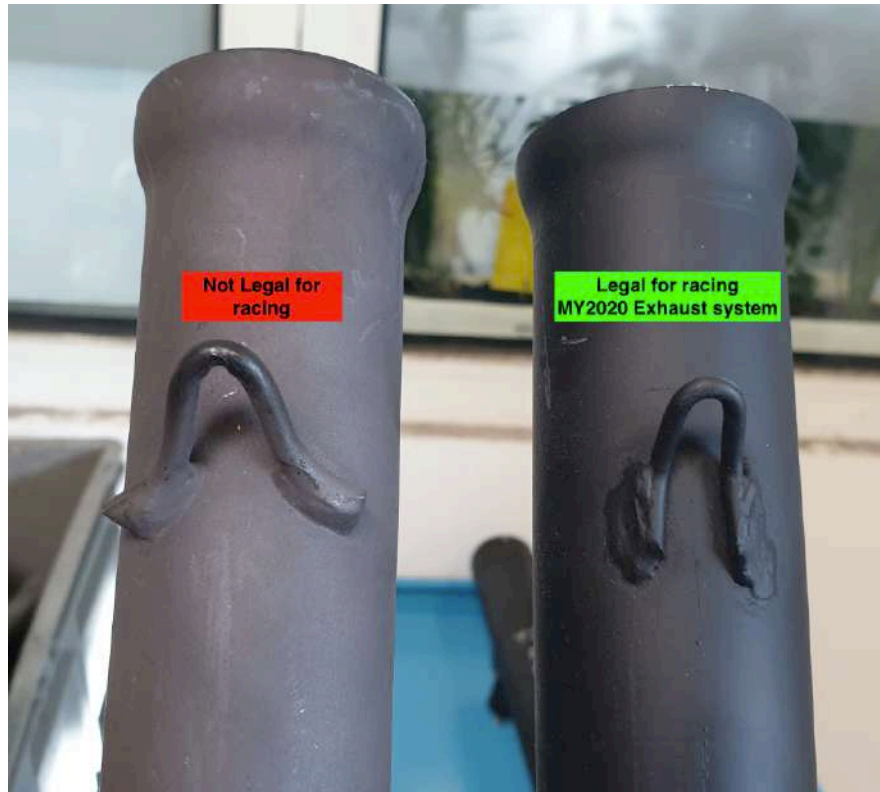

2.18. 125 Mini MAX:

A specific Exhaust system has to be used for the 125 Mini MAX engine.
ROTAX Part number 273137

The Exhaust external body is a common component to Micro MAX but with alternative internal components.

The silencer must be mounted in a position where the direction of the 90° elbow outlet (direction of the hot exhaust gasses) does not harm any component of the chassis.

The measurements in the diagram below are as follows:

- (a) 580 mm +/- 5mm
- (b) 299 mm +/- 5mm
- (c) 42 mm +/- 3mm

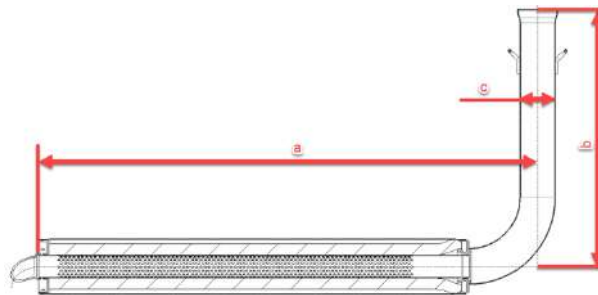

A steel ball with 28.0mm diameter **must not** pass through Section “A” and a steel ball with 26.0mm diameter must be able pass through Section “A” in the below diagram from the inlet and through the 90-degree elbow completely.
(Internal exhaust components must first be removed)

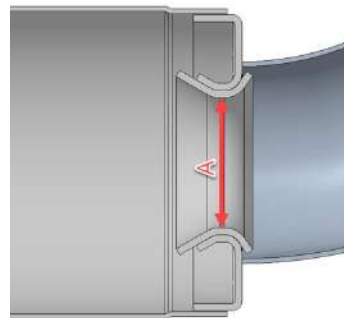

The inner measurement of the exhaust system silencer end (a) in the below diagram must be a maximum of 63.0 mm.

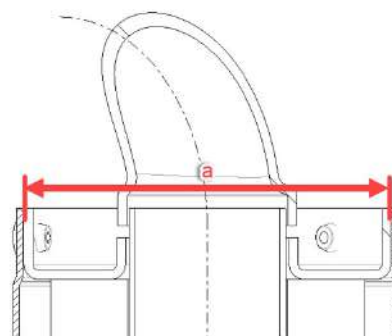

(Note: this is not a measurement of the perforated tube)

The Exhaust must be installed firmly to the chassis using a rigid mount/s.
The Exhaust must be mounted to the rigid mount/s using 2 ROTAX silent blocks.
(part 660920 and or 260657 allowed).
The deflection of the 2 silent blocks is the only Exhaust movement allowed.
The Exhaust must be mounted in a neutral position with no stress on the 2 silent blocks.

125 Mini MAX Perforated tube
ROTAX Part number 273211

The measurements in the diagram below are as follows:

- (a) at least 484 mm
- (b) minimum outside diameter of 61 mm
- (c) maximum outside diameter of 26 mm
- (d) at least 63 mm

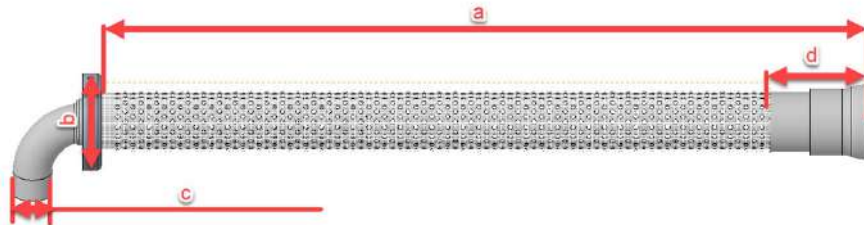

Note:
Mini MAX perforated tube has a stamped ID marker " X " visible externally.



The only legal Isolation matting for 125 Mini MAX is:
ROTAX part number 297985

New size minimum 490 x 180mm (+/-10mm)
New weight 141gr (119g – 163g)
Used weight minimum 110g
Used weight maximum 300g

2.19. Junior MAX and 125 Senior MAX:

A steel ball with 27,5 mm diameter must pass through the tuned pipe from the inlet and through the 180-degree elbow completely (silencer disconnected).

The silencer must be mounted in a position where the direction of the 90° elbow outlet (direction of the hot exhaust gasses) does not harm any component of the chassis.

Dimensions to be checked:

Length of inlet cone:	590mm +/-5mm
Length of cylindrical part of exhaust pipe:	130mm +/-5mm
Length of end cone:	230mm +/-5mm

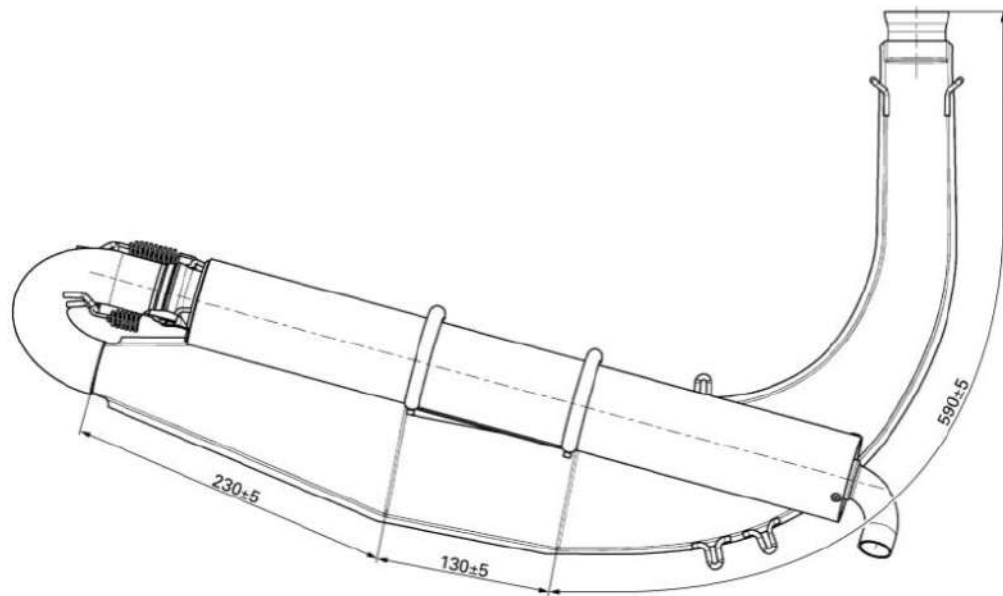

The only legal Isolation matting for 125 Junior and 125 Senior MAX is:
ROTAX part number 297982

New size minimum 480 x 270mm (+/-10mm)

New weight 207gr (176g – 238g)

Used weight minimum 140g

Used weight maximum 300g

2.20. 125 DD2 MAX:

The silencer must be mounted in a position where the direction of the 90° elbow outlet (direction of the hot exhaust gasses) does not harm any component of the chassis.

Dimensions to be checked:

Length of inlet cone:	575mm +/-5mm
Length of cylindrical part of exhaust pipe:	80mm +/-5mm
Length of end cone:	240mm +/-5mm

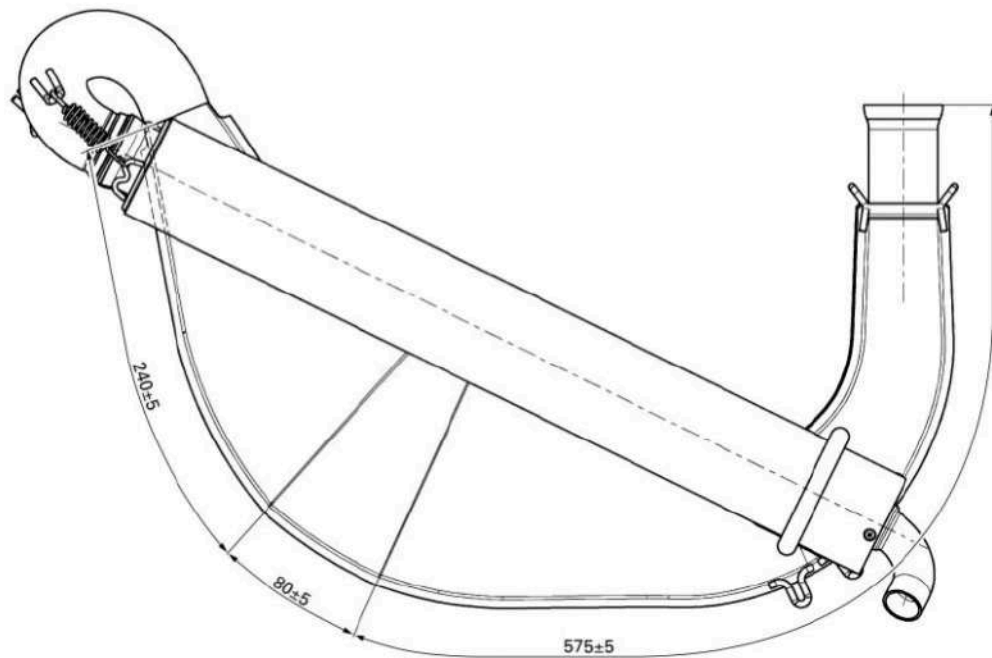

The only legal Isolation matting for 125 DD2 MAX is:
ROTAX part number 297982

New size minimum 480 x 270mm (+/-10mm)
New weight 207gr (176g – 238g)
Used weight minimum 140g
Used weight maximum 300g

2.21. Additional seat support (125 MAX DD2)

On the engine side, maximum one additional seat support can be used. The additional seat support must be fastened to the engine using the Allen screw (2). The distance sleeve (3) may be removed for this purpose.

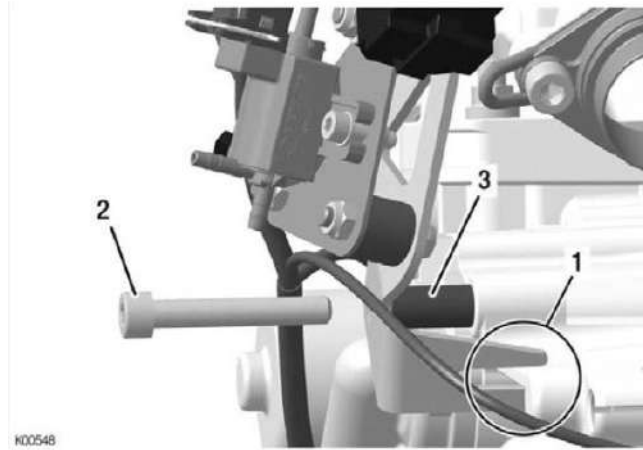

----- END OF TECHNICAL REGULATION -----